

Capilano inboard steering

Uncompromising Design. Capilano steering stands for ruggedness and reliability worldwide. Helms include a variable displacement feature enabling the helmsman to adjust the number of steering wheel turns to suit maneuvering and weather conditions. Capilano systems install easily and give years of dependable service.

SeaStar®
capilano

CAPILANO 1250V/1275V SYSTEM

Features:

- Variable displacement helms for adjustable number of steering wheel turns.
- Heavy duty brass cylinders with bleed fittings; chrome-plated stainless steel rods.
- Stainless steel and bronze mounting hardware.
- Easy installation on single and dual rudder vessels.
- Systems are not air-pressurized; no air leaks or pressure drops; separate reservoir not needed.
- Built-in pressure relief in helm protects system from effects of thermal expansion.
- Standard 3/4" tapered steering shaft.
- Meets ABS/Lloyd/Det Norske Veritas specifications.

Applications:

Most inboard powered boats with single or dual engines including planing/displacement hull craft from 30-55 feet in length. Suitable for dual station use with the purchase of extra helm, tubing/hose & fittings. Capilano systems use Dexron II® type ATF fluid.

(turns vary by system)

(SINGLE STATION)

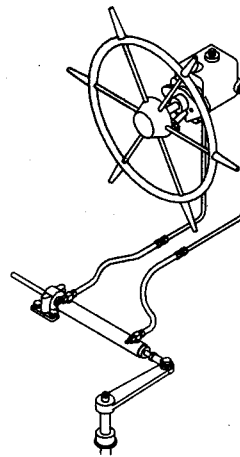

(DUAL STATION)

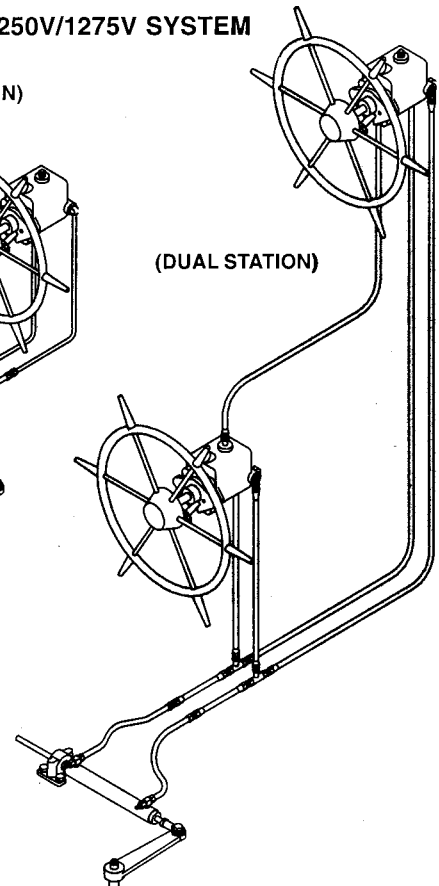

How to Spec a System:

1. From the application guide select components appropriate for the vessel based on:
 - a) hull type — displacement or planing;
 - b) length of vessel; and
 - c) number of steering wheel turns desired.
2. Select the fitting and hose kits required, based on type of plumbing (1/2" or 5/8" tubing or hose) and based on number of steering stations.
3. Confirm that there is sufficient space available in the dash and engine compartment(s) for the steering components.

Capilano inboard steering

Components:

Capilano 1250V Helm HH5250 or
Capilano 1275V Helm HH5275
(See application guide.)

Inboard Cylinder HC53__
(See application guide.)

Copper Tubing 1/2" or 5/8" OD
(See application guide.)

Fitting Kit (for 1/2" Copper Tubing) ... HF5590 or
Fitting Kit (for 5/8" Copper Tubing) HF5592
(See application guide.)

These fitting kits are for one steering station (purchase add-a-station kit for 2nd station).

Hose Kit for Copper Tubing (2 hoses) .. HA5731
This hose kit contains two 18" (.45m) hoses for single-cylinder installations.

Options:

Dual Cylinder Hose 2' (.6m) HA5732
Dual Cylinder Hose 3' (.9m) HA5733
Dual Cylinder Hose 4' (1.2m) HA5734
Dual Cylinder Hose 5' (1.5m) HA5735
Dual Cylinder Hose 6' (1.8m) HA5736

These hoses are sold individually (four are required for dual cylinder installations).

Fixed Mount Cylinder (13.3 cu. in.)
(one ball joint end) K-22
Fixed Mount Cylinder (13.3 cu. in.)
(two ball joint ends) K-27
Pivot Mount Cylinder (25.5 cu. in.) K-31
Universal Mount Cylinder (39.2 cu. in.) K-8
Universal Mount Cylinder (55 cu. in.) K-9

Add-A-Station Fitting Kit (1/2" tubing) .. HF5591
Add-A-Station Fitting Kit (5/8" tubing) .. HF5593
Helm Remote Fill Kit (through-dash) HA5450

Service Items:

Steering Fluid Dexron II® ATF
Steering Wheel Locknut 747521

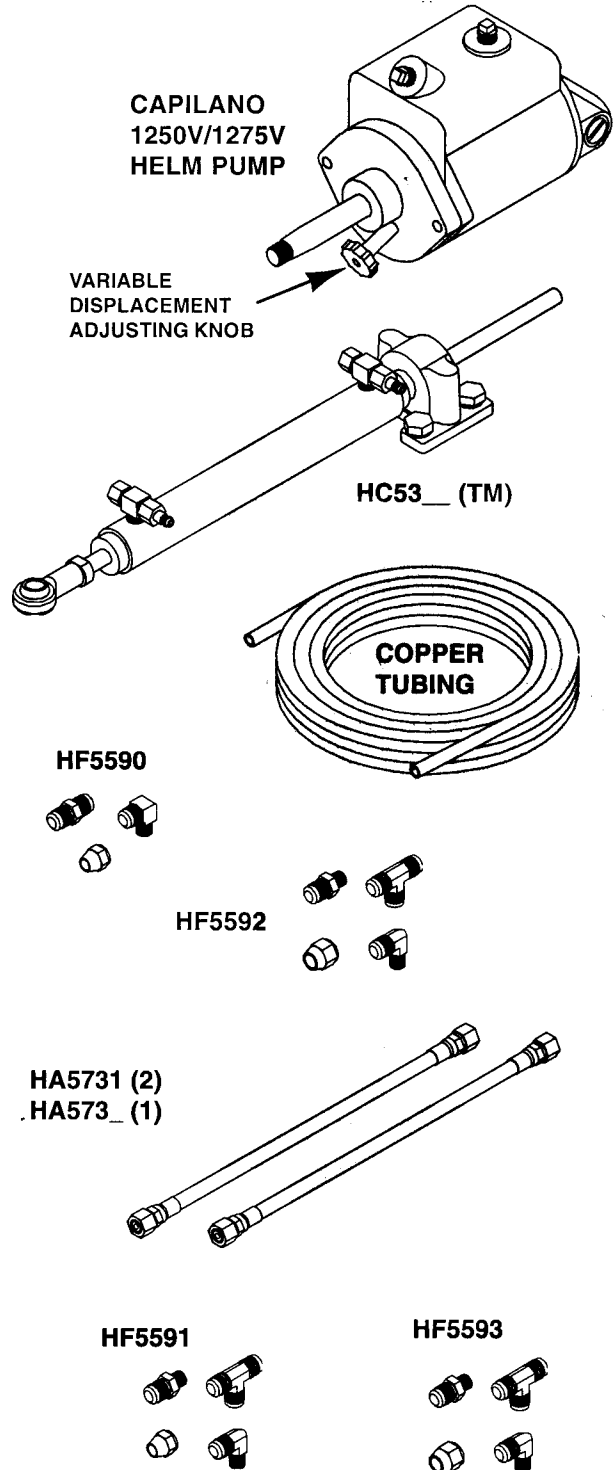

Capilano inboard steering

Application Guide: Capilano 2-Line Inboard Steering

This application guide should be used with discretion. The chart below is only a guide to selecting a steering system.

A steering system manufacturer cannot anticipate all the variables in boat-rudder design that affect steering loads. It is the final responsibility of the boat designer/builder to specify maximum expected steering loads.



If the required information is not available, contact us with rudder dimensions, vessel size and anticipated maximum vessel speed for a recommendation.

Definitions of terms used in the charts on these pages:

Planing Hull: maximum hull speed normally exceeds 18 knots.

Displacement Hull: maximum hull speed does not normally exceed 18 knots.

Diameters: Copper tubing diameter shown is O.D. Hose diameter shown is I.D.

FOR VESSEL SIZES UP TO:	HELM PUMP MODEL	STEERING WHEEL TURNS ADJUST. RANGE Min.-Max.	REQUIRES CYLINDER MODEL (2x = 2 cylinders)	TUBING/HOSE DIAMETERS when distance from Cylinder to farthest Helm is:		MAXIMUM OUTPUT TORQUE FROM CYLINDER(S)	
				40 Feet or Less	40 Feet or More	In.-Lb.	Kg m
PLANING HULLS: 							
35' (11m)	1250V	3 - 6	BA150-7TM_	1/2"	N/A	6,548	75
40' (12m)	1250V	4 - 8	BA175-7TM_	1/2"	N/A	8,795	100
50' (15m)	1250V	5.5 - 11	BA200-7TM_	1/2"	5/8"	12,134	140
50' (15m)	1275V	3.5 - 7	BA200-7TM_	1/2"	5/8"	12,134	140
50' (15m)	1275V	4 - 8	2x BA150-7TM_	1/2"	5/8"	14,766	170
55' (17m)	1275V	5.5 - 11	BA200-11 TM_	1/2"	5/8"	19,900	230
55' (17m)	1275V	5.5 - 11	2x BA175-7TM_	1/2"	5/8"	19,902	230
60' (18m)	1275V	7.5 - 15	2x BA200-7TM_	1/2"	5/8"	26,322	300
DISPLACEMENT HULLS: 							
30' (9m)	1250V	3 - 6	BA150-7TM_	1/2"	N/A	6,548	75
38' (11.5m)	1250V	4 - 8	BA175-7TM_	1/2"	N/A	8,795	100
45' (14m)	1250V	5.5 - 11	BA200-7TM_	1/2"	5/8"	12,134	140
45' (14m)	1275V	3.5 - 7	BA200-7TM_	1/2"	5/8"	12,134	140
45' (14m)	1275V	4 - 8	2x BA150-7TM_	1/2"	5/8"	14,766	170
50' (15m)	1275V	5.5 - 11	BA200-11 TM_	1/2"	5/8"	19,900	230
50' (15m)	1275V	5.5 - 11	2x BA175-7TM_	1/2"	5/8"	19,902	230
50' (15m)	1275V	7.5 - 15	2x BA200-7TM_	1/2"	5/8"	26,322	300

NOTE: Theoretical torque about pivot point at 35 degree articulation with 1,000 PSI (70 BAR) system pressure.

Phone: 800-225-0004  Fax: 908-486-1056
e-mail: sales@sealandpower.com

Capilano inboard steering

Helm Options

A unique variable displacement feature on the helm allows the number of steering wheel turns to be adjusted by the helmsman to his preference within a pre-determined range.

Tubing/Hose Options

We recommend use of soft refrigeration type copper tubing for optimum performance. If hose must be used, select a hydraulic hose rated for 1000 PSI (70 bar) working pressure, and with a very low volumetric expansion rating. A hydraulic hose that expands too much at 500 PSI (35 bar) will make the steering spongy.

Cylinder Options

Cylinders are made from brass & stainless steel. Available with stainless rod & ball joint (TMB models) or stainless rod & bronze clevis (TMC models.) Cylinders with ball joints have 2-axis articulation.

PART NO.	DESCRIPTION/MODEL/ROD END CONFIG.
7" STROKE MODELS:	
HC5349	Cylinder BA150-7TMB (rod end ball joint)
HC5350	Cylinder BA175-7TMB (rod end ball joint)
HC5351	Cylinder BA200-7TMB (rod end ball joint)
HC5355	Cylinder BA150-7TMC (rod end clevis)
HC5356	Cylinder BA175-7TMC (rod end clevis)
HC5357	Cylinder BA200-7TMC (rod end clevis)
11" STROKE MODELS:	
HC5378	Cylinder BA200-11TMB (rod end ball joint)
HC5379	Cylinder BA200-11TMC (rod end clevis)

Also available are fixed mount cylinders K-22/ K-27 (13.3 cu. in. displacement); pivot mount cylinder K-31 (25.5 cu. in.); and universal mount cylinders K-8 (39.2 cu. in.) and K-9 (55 cu. in.). Number of wheel turns is based on total cylinder displacement divided by helm displacement.

HELM PART #	MODEL	DISPLACEMENT ADJUSTMENT RANGE	RELIEF VALVE SETTING
HH5250	1250V	1.7-3.4 cu.in. (27.8-55.7 cc)	1000 PSI (70 BAR)
HH5275	1275V	2.7-5.4 cu.in. (44.2-88.4 cc)	1000 PSI (70 BAR)

HELM TYPE	DISTANCE — CYLINDER TO FURTHEST HELM	
	40 Feet or Less	More Than 40 Feet
1250V	1/2" O.D. Copper Tubing	5/8" O.D. Copper Tubing
	1/2" I.D. Hydraulic Hose	5/8" I.D. Hydraulic Hose
1275V	5/8" O.D. Copper Tubing	5/8" O.D. Copper Tubing
	5/8" I.D. Hydraulic Hose	5/8" I.D. Hydraulic Hose

Typical Capilano Dual Station System:

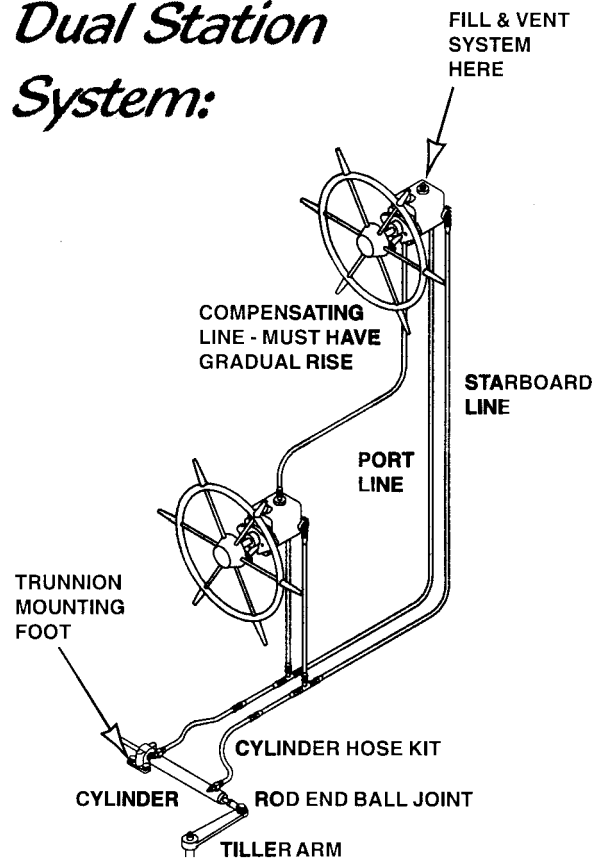

Phone: 800-225-0004 Fax: 908-486-1056
e-mail: sales@sealandpower.com

Hynautic inboard steering

SeaStar offers rugged 3-line Hynautic Heavy Duty steering systems for most work and pleasure vessels up to 70 feet.

Heavy Duty helms combine one or two bi-directional axial piston pumps with pilot check and make-up check valving. The result is a unit which prevents rudder feedback, is very efficient (even at low RPM), and is immediately adaptable to multi-station use.

A wide choice of helm displacements and cylinder configurations make it easy to spec a system which can handle a variety of large boat performance requirements and accommodate most user preferences.

Features:

- Low friction heavy duty hydraulic steering.
- Helm/cylinder combinations for most inboards. Marine grade materials.
- Heavy duty helms available in three displacements, to accommodate most applications and user preferences.
- Helms available with 1" straight shaft or 3/4" tapered. Mount facing any direction.
- Quick air purge relief valve.
- Fluid fill at remote reservoir.
- Heavy duty brass cylinders. Two-axis articulation. Easy installation for single or dual rudder vessels.
- Meets or exceeds applicable standards.
- Accepts most steering wheels.

(turns vary by system)

SeaStar®

Hynautic®

**HYNAUTIC®
3-LINE DUAL STATION
INBOARD SYSTEM**

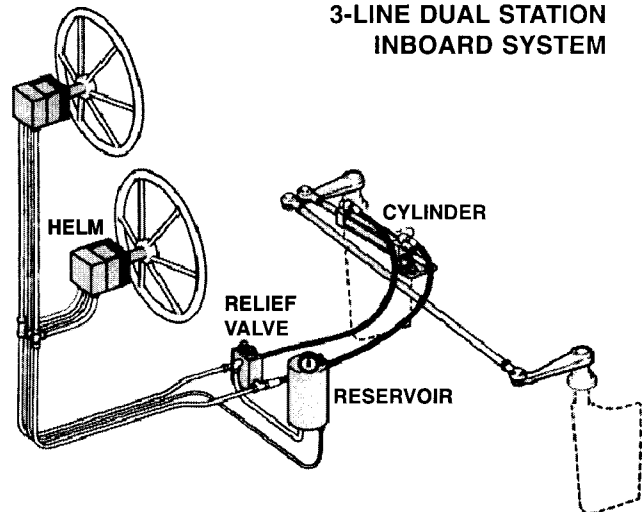

How to Spec a System:

1. From the application guide select components appropriate for the vessel based on:
 - a) hull type — displacement or planing;
 - b) length of vessel; and
 - d) number of steering wheel turns desired.
2. Select the fitting and hose kits required, based on type of plumbing (1/2" or 5/8" tubing or hose) and based on number of steering stations.
3. Confirm that there is sufficient space available in the dash and engine compartment(s) for the steering components.

Hynautic inboard steering

Components:

Hynautic 2.75 cu. in. helm (1" straight shaft)	H-21 or
Hynautic 2.75 cu. in. helm (3/4" tapered shaft)	H-25 or
Hynautic 4.0 cu. in. helm (1" straight shaft)	H-42 or
Hynautic 4.0 cu. in. helm (3/4" tapered shaft)	H-42-02 or
Hynautic 5.5 cu. in. helm (1" straight shaft)	H-41 or
Hynautic 5.5 cu. in. helm (3/4" tapered shaft)	H-41-02 or
<i>(See application guide on next page.)</i>	
H-20 Fittings Kit for Main Station	HF-10
H-40 Fittings Kit for Main Station	HF-21

Inboard Cylinder HC53__ or K__
(See application guide on next page. 1 or 2 required.)

Reservoir - Standard (2 quart) R06
Relief Valve (950 PSI) MSV-21
Relief Fittings (1150 & 1175-21-1)..... MSVF-07
Relief Fittings (1175-42-1 & up) MSVF-13
Copper Tubing 1/2" or 5/8" OD
(See application guide on next page.)

Fitting Kit (for 1/2" Copper Tubing) HF5590 or K-__
Fitting Kit (for 5/8" Copper Tubing) HF5592
(See application guide on next page. These fitting kits are for one steering station; purchase add-a-station kit for 2nd station.)

Hose Kit for Copper Tubing (2 hoses) HA5731
Contains two 18" (.45m) hoses for single-cylinder installations.
SeaStar Oil (1 Gallon) HA5440



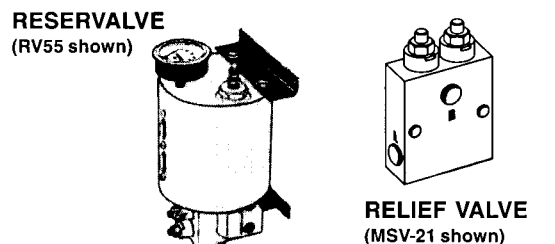
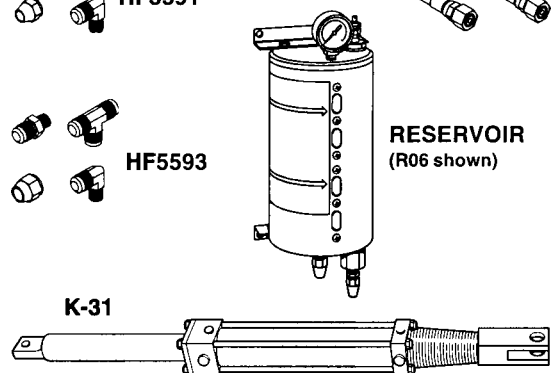
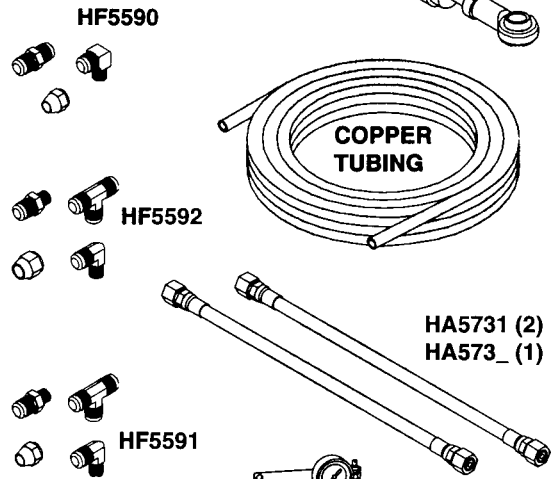
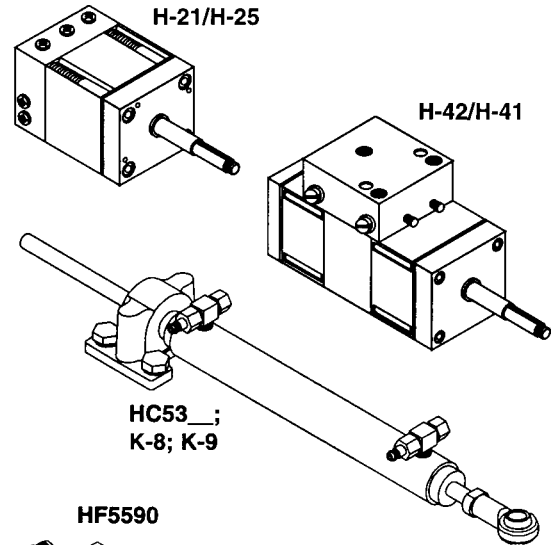

Options:

Pivot Mount Inboard Cylinder	K-31
<i>(Systems 8a & 8b; see "Cylinder Options" on p. 117.)</i>	
Dual Cylinder Hose 2' (.6m)	HA5732
Dual Cylinder Hose 3' (.9m)	HA5733
Dual Cylinder Hose 4' (1.2m)	HA5734
Dual Cylinder Hose 5' (1.5m)	HA5735
Dual Cylinder Hose 6' (1.8m)	HA5736
<i>These hoses are sold individually (four are required for dual cylinder installations).</i>	
Reservoir (2 quart, with hand pump)	R07
Reservoir (1 quart, with hand pump)	R11
Reservoir (2 quart)	R12
Relief Valve (500 PSI)	MSV-19
Reservale (500 PSI, top read, 3/8)	RV-55
Reservale (500 PSI, top read, 3/8, w/pump) ..	RV-55P
Reservale (500 PSI, top read, 5/16, w/pump) ..	RV-57
Reservale (950 PSI, top read, 5/16)	RV-60
Reservale (950 PSI, frt.read, 5/16, w/pump) ..	RV-67
H-20 Fittings Kit for Second Station	HF-11
H-40 Fittings Kit for Second Station	HF-22



Phone: 800-225-0004 Fax: 908-486-1056
e-mail: sales@sealandpower.com

Application Guide: 3-Line Inboard Steering

FOR VESSEL SIZES UP TO:	HELM PUMP MODEL	STEERING WHEEL TURNS	REQUIRES CYLINDER MODEL (2x = 2 cylinders)	TUBING DIAMETERS		MAX. SUGG. H.P.	MAX. SUGG. AREA FEET (meters)
				when distance from Cylinder to farthest Helm is: 40 Feet or Less	40 Feet or More		
PLANING HULLS: 							
35-50' (11-15m)	H-21 or H-25	5.0	HC5350 or HC5356	1/2"	5/8"	450	—
40-50' (10-18m)	H-21 or H-25	6.8	HC5351 or HC5357	1/2"	5/8"	750	—
40-50' (10-18m)	H-42	4.7	HC5351 or HC5357	1/2"	5/8"	750	—
45-60' (14-18m)	H-42	7.4	HC5378 or HC5379	1/2"	5/8"	950	—
45-60' (14-18m)	H-41	5.4	HC5378 or HC5379	1/2"	5/8"	950	—
55-65' (17-20m)	H-41	5.4	HC5378 or HC5379	1/2"	5/8"	1200	—
to 70' (to 21m)	H-41	10.8	2x HC5378 or HC5379	1/2"	5/8"	1500	—
to 70' (to 21m)	H-41	14.2	2x K-8	1/2"	5/8"	1500	—
DISPLACEMENT HULLS — TUG BOATS, NET HAULERS: 							
to 30' (6-9m)	H-21 or H-25	5.0	HC5350 or HC5356	1/2"	5/8"	200	—
30-35' (6-11m)	H-21 or H-25	6.8	HC5351 or HC5357	1/2"	5/8"	250	—
30-35' (6-11m)	H-42	4.7	HC5351 or HC5357	1/2"	5/8"	250	—
26-40' (8-12m)	H-42	7.4	HC5378 or HC5379	1/2"	5/8"	400	—
26-40' (8-12m)	H-41	5.4	HC5378 or HC5379	1/2"	5/8"	400	—
30-45' (9-14m)	H-41	5.4	HC5378 or HC5379	1/2"	5/8"	450	—
to 50' (to 15m)	H-41	10.8	2x HC5378 or HC5379	1/2"	5/8"	500	—
to 50' (to 15m)	H-41	14.2	2x K-8	1/2"	5/8"	500	—
to 50' (to 15m)	H-41	20.0	2x K-9	1/2"	5/8"	500	—
DISPLACEMENT HULLS — WORK & PLEASURE BOATS: 							
to 40' (9-12m)	H-21 or H-25	5.0	HC5350 or HC5356	1/2"	5/8"	300	—
40-45' (12-14m)	H-21 or H-25	6.8	HC5351 or HC5357	1/2"	5/8"	350	—
40-45' (12-14m)	H-42	4.7	HC5351 or HC5357	1/2"	5/8"	350	—
40-55' (12-17m)	H-42	7.4	HC5378 or HC5379	1/2"	5/8"	500	—
40-55' (12-17m)	H-41	5.4	HC5378 or HC5379	1/2"	5/8"	500	—
45-65' (14-20m)	H-41	5.4	HC5378 or HC5379	1/2"	5/8"	650	—
to 75' (to 23m)	H-41	10.8	2x HC5378 or HC5379	1/2"	5/8"	750	—
to 75' (to 23m)	H-41	14.2	2x K-8	1/2"	5/8"	750	—
SAILBOATS — SKEG RUDDER: 							
to 40' (9-12m)	H-21 or H-25	5.0	HC5350 or HC5356	1/2"	5/8"	—	9 (.9)
40-45' (12-14m)	H-21 or H-25	6.8	HC5351 or HC5357	1/2"	5/8"	—	10 (1)
40-45' (12-14m)	H-42	4.7	HC5351 or HC5357	1/2"	5/8"	—	10 (1)
40-52' (12-16m)	H-42	7.4	HC5378 or HC5379	1/2"	5/8"	—	17 (1.6)
40-52' (12-16m)	H-41	5.4	HC5378 or HC5379	1/2"	5/8"	—	17 (1.6)
50-60' (15-18m)	H-41	5.4	HC5378 or HC5379	1/2"	5/8"	—	18 (1.7)
to 65' (to 20m)	H-41	10.8	2x HC5378 or HC5379	1/2"	5/8"	—	20 (1.9)
to 65' (to 20m)	H-41	14.2	2x K-8	1/2"	5/8"	—	20 (1.9)
SAILBOATS — SPADE RUDDER: 							
to 40' (9-12m)	H-21 or H-25	5.0	HC5350 or HC5356	1/2"	5/8"	—	7 (.6)
40-45' (12-14m)	H-21 or H-25	6.8	HC5351 or HC5357	1/2"	5/8"	—	8 (.7)
40-45' (12-14m)	H-42	4.7	HC5351 or HC5357	1/2"	5/8"	—	8 (.7)
35-46' (11-16m)	H-42	7.4	HC5378 or HC5379	1/2"	5/8"	—	15 (1.4)
35-46' (11-16m)	H-41	5.4	HC5378 or HC5379	1/2"	5/8"	—	15 (1.4)
40-50' (12-15m)	H-41	5.4	HC5378 or HC5379	1/2"	5/8"	—	15.5 (1.4)
to 60' (to 18m)	H-41	10.8	2x HC5378 or HC5379	1/2"	5/8"	—	16.5 (1.5)
to 60' (to 18m)	H-41	14.2	2x K-8	1/2"	5/8"	—	16.5 (1.5)

Hynautic inboard steering

Helm Options

Four helms are offered in 3 displacements, as noted in the chart at right. The H-21 helm has a 1" straight wheel shaft; H-25 has a 3/4" tapered shaft. The H-42 and H-41 helms both have a 1" straight wheel shaft.

HELM PART #	DISPLACEMENT RANGE	RELIEF VALVE SETTING
H-21	2.75 cu. in.	950 PSI
H-25	2.75 cu. in.	(66 BAR)
H-42	4.0 cu. in.	950 PSI
H-41	5.5 cu. in.	(66 BAR)

Tubing/Hose Options

Use soft refrigeration type copper tubing for optimum performance. For tube-to-cylinder flex hoses, select a hydraulic hose rated for 1000 PSI (70 bar) working pressure, and with a very low volumetric expansion rating.

HELM TYPE	DISTANCE — CYLINDER TO FURTHEST HELM	
	40 Feet or Less	More Than 40 Feet
ALL	1/2" O.D. Copper Tubing	5/8" O.D. Copper Tubing

Cylinder Options

Cylinders are made from brass & stainless steel. Available with stainless rod & ball joint (TMB models) or stainless rod & bronze clevis (TMC models.) Cylinders with ball joints have 2-axis articulation.

The K-31 is an optional pivot mount cylinder which can be used in the systems numbered "8a" and "8b" on the opposite page. With this cylinder, the number of wheel turns becomes 6.4 (using the H-42 helm) or 4.6 (H-41 helm).

PART NO.	DESCRIPTION/MODEL/ROD END CONFIG.
7" STROKE MODELS:	
HC5350	Cylinder BA175-7TMB (rod end ball joint)
HC5356	Cylinder BA175-7TMC (rod end clevis)
HC5351	Cylinder BA200-7TMB (rod end ball joint)
HC5357	Cylinder BA200-7TMC (rod end clevis)
9.5" STROKE MODEL:	
K-8	Hynautic Cylinder, 2.5" bore (rod end ball joint)
11" STROKE MODELS:	
HC5378	Cylinder BA200-11TMB (rod end ball joint)
HC5379	Cylinder BA200-11TMC (rod end clevis)

The application guide should be used with discretion. The chart is only a guide to selecting a steering system. A steering system manufacturer cannot anticipate all the variables in boat-rudder design that affect steering loads. It is the final responsibility of the boat designer/builder to specify maximum expected steering loads. If the required information is not available, contact our customer service department with rudder dimensions, vessel size and anticipated maximum vessel speed.

Definitions of terms used in the charts on these pages:

Planing Hull: maximum hull speed normally exceeds 18 knots.

Displacement Hull: maximum hull speed does not normally exceed 18 knots.

Diameters: Copper tubing diameter shown is O.D. Hose diameter shown is I.D.

SeaStar inboard steering

The most popular inboard hydraulic steering system offers unmatched comfort and control for today's inboards up to 50 feet. A wide range of helm and cylinder displacements covers most applications.

SeaStar®

Hynautic®

Features:

- Low friction hydraulic steering system.
- Configurations for most inboards.
- Compact helm has only a 4-7/16" footprint — needs only 3" dash hole (Tilt requires larger hole).
- Standard 3/4" tapered steering shaft.
- Easy installation on single or dual rudders.
- Cylinders supplied with bleeder fittings.
- Regular duty aluminum or heavy duty brass cylinders. Two-axis articulation.
- Meets A.B.Y.C. standards.
- Meets N.M.M.A. certification requirements.
- Accepts steering wheels to 28" (20" for Tilt)

SEASTAR®
2-LINE
INBOARD SYSTEM

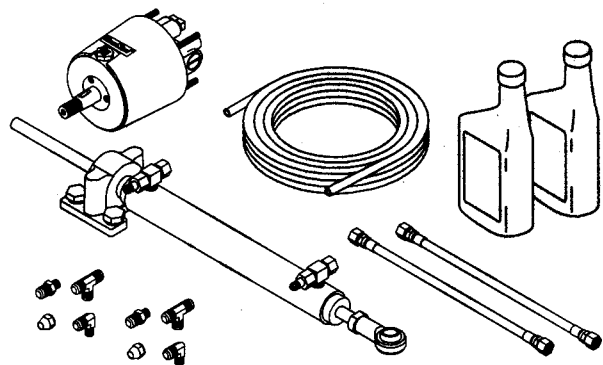

Applications:

Most inboard powered boats with single or dual engines: single engine planing/displacement hull craft from 26-44 feet; dual engine planing hull craft from 26-50 feet; dual engine displacement hull & sail craft from 26-44 feet. Suitable for dual station use with purchase of extra hardware.

(turns vary by system)



How to Spec a System:

1. From the application guide select the System Number appropriate for the vessel based on:
 - a) hull type — displacement or planing;
 - b) length of vessel;
 - c) number of rudders; and
 - d) usage of vessel.
2. From the ordering guide select the appropriate helm and accessory hardware for each steering station.
3. Select fitting/hose kits required from the ordering guide.
4. Confirm that there is sufficient space available in the dash and engine compartment(s) for the steering components. Review helm and cylinder dimensions

SeaStar inboard steering

Components:

- SeaStar 1.7 Helm HH5271 or
SeaStar 2.4 Helm HH5272
(See ordering guide.)
Inboard Cylinder HC53__ or K-?
(See ordering guide.)
3/8" Tubing HT5__ or copper
(See ordering guide.)
Fitting Kit (for Copper Tubing/1.7 helm) HF5507
Hose Kit for Copper Tubing (2 hoses) .. HF5508
SeaStar Oil (1 Quart Mil Spec H5606) . HA5430

Options:

- SeaStar 1.7 Sport Tilt Helm/Mech. HH5291
SeaStar 1.7 Traditional Tilt Helm/Mech. . HH5741
SeaStar 2.4 Sport Tilt Helm/Mech. HH5292
SeaStar 2.4 Traditional Tilt Helm/Mech. . HH5742
SeaStar 1.7 Rear Mount Helm HH5261

- SeaStar 1.7 Commercial Duty Helm HH5217
SeaStar 2.4 Commercial Duty Helm HH5224
(Designed for small Lobster and Crabbing vessels, these helms have a stainless steel shaft with heavy duty seal and wiper, which help protect the helm from the abrasive effects of sediment brought on board with traps or pots.)

- SeaStar Round Bezel Kit HA5417
(Reduces helm protrusion by 3.75")
SeaStar Backplate Kit HA5418
(Reduces helm protrusion by dash thickness and allows clean retrofit of SeaStar helm where following helms were installed: pre-1991 SeaStar, SyTen, and mechanical rotary steering.)
SeaStar 20° Dash Wedge Kit HA5419
Ball Joint Mount Cylinder (7 cu. in.) K-18
Ball Joint Mount Cylinder (9 cu. in.) K-19
Fixed Mount Cylinder (13.3 cu. in.)
(one ball joint end) K-22
Fixed Mount Cylinder (13.3 cu. in.)
(two ball joint ends) K-27
Add-A-Station/Autopilot Fittings Kit HF5502
SeaStar Hose Kit (2 hoses) HO51__

Service Items:

- SeaStar Oil (1 Gallon) HA5440
Steering Wheel Locknut 747521

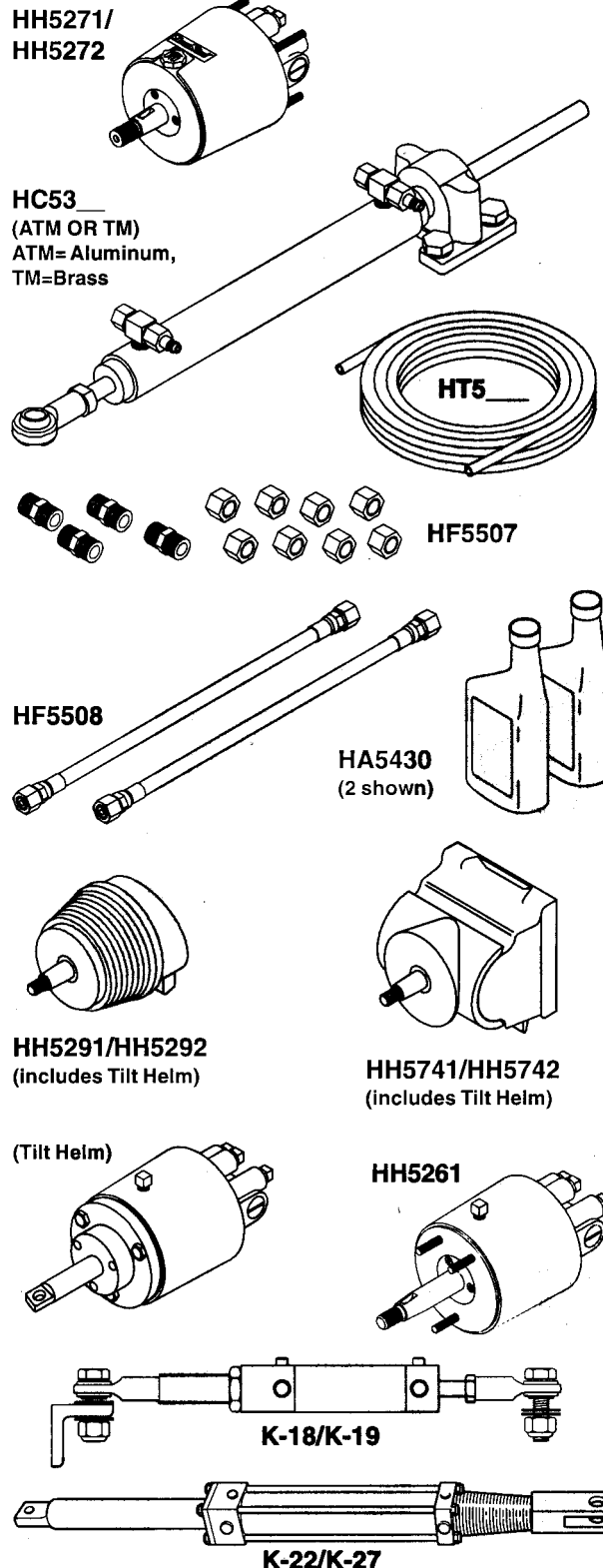

Application Guide (inboard steering)

Use "System Numbers" in chart below to select the components from ordering guide on next page.

BOAT TYPE/ LENGTH	System Numbers 1 ENGINE		System Numbers 2 ENGINES	
	Pleasure	Work	Pleasure	Work
PLANING HULLS				
To 26 Ft. (8m)	1	4	1	4
To 32 Ft. (10m)	2	4	1	4
To 38 Ft. (11.5m)	3	5	2	5
To 44 Ft. (13.5m)	5	—	3	5
To 50 Ft. (15m)	—	—	5	—
DISPLACEMENT HULLS				
To 26 Ft. (8m)	2	4	2	4
To 32 Ft. (10m)	3	4	3	4
To 38 Ft. (11.5m)	5	5	3	5
To 44 Ft. (13.5m)	—	—	5	—
To 50 Ft. (15m)	—	—	—	—
SAIL				
To 26 Ft. (8m)	4	4	—	—
To 32 Ft. (10m)	4	4	—	—
To 38 Ft. (11.5m)	4	5	—	—
To 44 Ft. (13.5m)	5	—	—	—
To 50 Ft. (15m)	—	—	—	—

Inboard Cylinder Dimensions

ATM (ALUMINUM BODY) INBOARD CYLINDERS
P/N HC5312/HC5313/HC5314 (MODEL BA1__7ATM):

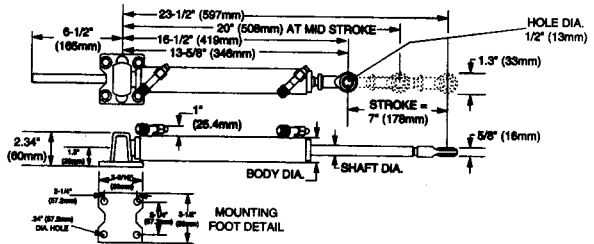

TM (BRASS BODY) INBOARD CYLINDERS
P/N HC5318/HC5319 (MODEL BA1__7TM):

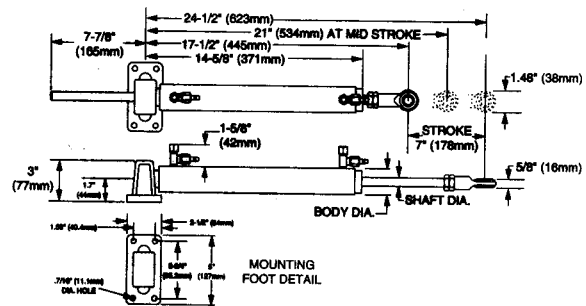

Planing Hull: maximum hull speed normally exceeds 18 knots.
Displacement Hull: maximum hull speed does not normally exceed 18 knots.

CYLINDER DIMENSIONS & MOUNTING CONFIGURATIONS SPECIFIC TO MODEL							
CYLINDER MODEL	PART NO.	BODY DIAMETER (SEE DIAGRAMS ABOVE)	SHAFT DIAMETER	DIM.		DIM. C	
				A	B		
BA125-7ATM	HC5312	1.38" (35mm)	.50" (12.7mm)	20" (508mm)	6.5" (165mm)	8.5" (216mm)	
BA135-7ATM	HC5313	1.50" (38mm)	.63" (15.9mm)	20" (508mm)	6.5" (165mm)	8.5" (216mm)	
BA150-7ATM	HC5314	1.75" (45mm)	.63" (15.9mm)	20" (508mm)	6.5" (165mm)	8.5" (216mm)	
BA150-7TM	HC5318	1.75" (45mm)	.63" (15.9mm)	21" (534mm)	8.0" (204mm)	10.0" (254mm)	
BA150-9TM	HC5369	1.75" (45mm)	.63" (15.9mm)	21" (534mm)	8.0" (204mm)	10.0" (254mm)	
BA175-7TM	HC5319	2.00" (45mm)	.75" (19.1mm)	21" (534mm)	8.0" (204mm)	10.0" (254mm)	

Ordering Guide: 2-Line Inboard Steering

ENGINE/CYLINDER CONFIGURATION	COMPONENT DESCRIPTION	QTY. REQ'D	MODEL	PART NO.	
SYSTEM #1 <u>NUMBER OF TURNS: 4.0</u>	CYLINDER	1	BA125-7ATM	HC5312	
	HELM	1	SEASTAR 1.7	HH5271	
	TUBING (SEE NOTES 1 & 3)		3/8" DIA. NYLON	HT5____	
	OIL	3	SEASTAR OIL (QT.)	HA5430	
	FOR EXTRA STEERING STATION, ADD:	HELM	1	SEASTAR 1.7	HH5271
	FITTING KIT	1	ADD A STATION	HF5502	
	EXTRA TUBING (SEE NOTES 1 & 3)		3/8" DIA. NYLON	HT5____	
OIL	1	SEASTAR OIL (QT.)	HA5430		
SYSTEM #2 <u>NUMBER OF TURNS: 5.0</u>	CYLINDER	1	BA135-7ATM	HC5313	
	HELM	1	SEASTAR 1.7	HH5271	
	TUBING (SEE NOTES 1 & 3)		3/8" DIA. NYLON	HT5____	
	OIL	3	SEASTAR OIL (QT.)	HA5430	
	FOR EXTRA STEERING STATION, ADD:	HELM	1	SEASTAR 1.7	HH5271
	FITTING KIT	1	ADD A STATION	HF5502	
	EXTRA TUBING (SEE NOTES 1 & 3)		3/8" DIA. NYLON	HT5____	
OIL	1	SEASTAR OIL (QT.)	HA5430		
SYSTEM #3 <u>NUMBER OF TURNS: 6.0</u>	CYLINDER	1	BA150-7ATM	HC5314	
	HELM	1	SEASTAR 1.7	HH5271	
	TUBING (SEE NOTES 1 & 3)		3/8" DIA. NYLON	HT5____	
	OIL	3	SEASTAR OIL (QT.)	HA5430	
	FOR EXTRA STEERING STATION, ADD:	HELM	1	SEASTAR 1.7	HH5271
	FITTING KIT	1	ADD A STATION	HF5502	
	EXTRA TUBING (SEE NOTES 1 & 3)		3/8" DIA. NYLON	HT5____	
OIL	1	SEASTAR OIL (QT.)	HA5430		
SYSTEM #4 <u>NUMBER OF TURNS: 4.25</u>	CYLINDER	1	BA150-7TM	HC5318	
	HELM	1	SEASTAR 2.4	HH5272	
	TUBING (SEE NOTES 1 & 3)		3/8" DIA. COPPER		
	HOSE KIT	1	SEASTAR HOSE KIT	HF5508	
	OIL	3	SEASTAR OIL (QT.)	HA5430	
	FOR EXTRA STEERING STATION, ADD:	HELM	1	SEASTAR 2.4	HH5272
	FITTING KIT	1	ADD A STATION	HF5502	
EXTRA TUBING (SEE NOTES 1 & 3)		3/8" DIA. COPPER			
OIL	1	SEASTAR OIL (QT.)	HA5430		
SYSTEM #5 <u>NUMBER OF TURNS: 5.5</u>	CYLINDER	1	BA175-7TM	HC5319	
	HELM	1	SEASTAR 2.4	HH5272	
	TUBING (SEE NOTES 1 & 3)		3/8" DIA. COPPER		
	HOSE KIT	1	SEASTAR HOSE KIT	HF5508	
	OIL	3	SEASTAR OIL (QT.)	HA5430	
	FOR EXTRA STEERING STATION, ADD:	HELM	1	SEASTAR 2.4	HH5272
	FITTING KIT	1	ADD A STATION	HF5502	
EXTRA TUBING (SEE NOTES 1 & 3)		3/8" DIA. COPPER			
OIL	1	SEASTAR OIL (QT.)	HA5430		
OPTIONAL EQUIPMENT	BACK PLATE KIT		(FOR STANDARD HELMS)	HA5418	
	20 DEGREE WEDGE		(FOR STANDARD HELMS)	HA5419	
	AUTOPILOT FITTING KIT		(FOR ALL HELMS)	HF5501	
	TILT HELM - SEASTAR 1.7		(TRADITIONAL: HH5741; SPORT:	HH5291)	
	REAR MOUNT HELM - SEASTAR 1.7			HH5261	
	TILT HELM - SEASTAR 2.4		(TRADITIONAL: HH5742; SPORT:	HH5292)	
	REAR MOUNT HELM - SEASTAR 2.4			HH5262	

For systems 1, 2, & 3, nylon tubing (3/8" diameter) is the standard requirement for plumbing the system. Copper tubing (3/8" diameter) can be substituted by Fitting Kit HF5507 is required. For systems 4 & 5, copper tubing (3/8" diameter) is the standard requirement for plumbing the system. Fitting Kit HF5508 is required. For systems 1, 2, 3, 4, & 5, SeaStar outboard hose can be substituted for nylon or copper tube. These hoses must be ordered in standard lengths. They cannot be cut to length.

Phone: 800-225-0004 ☎ Fax: 908-486-1056
e-mail: sales@sealandpower.com

BayStar outboard steering

With mechanical steering you sacrifice a degree of comfort, and traditional hydraulic systems may be more than is needed on lower horsepower outboard engines. The solution is finally here—BayStar!

Built in the tradition of SeaStar — the industry leading hydraulic steering — BayStar brings the same safety and comfort now common on larger outboards to boats with outboards up to 150 HP.

Features:

- Designed just for smaller outboards.
- Low friction hydraulic steering system.
- 4.5 turns from lock-to-lock.
- Balanced cylinder, featuring a compact design that fits most splashwells.
- Cylinder provides full engine movement.
- Optional five position tilt helm available.
- Compact helm has only a 5" footprint; needs only 3" dash hole (standard or Tilt).
- Packaged complete with helm, cylinder, fittings, tubing, oil, fill kit and detailed instructions.
- Standard 3/4" tapered steering shaft.
- Fast, easy installation.
- Meets A.B.Y.C. standards.
- Meets N.M.M.A. certification requirements.

Note: BayStar is NOT suitable for smaller HP outboard engines that use wing nut type transom mount clamping screws.

Applications:

BayStar is for single-outboard powered boats rated up to 150 HP, including runabouts and inflatables — and outboard engines with ABYC standard engine tilt tubes up to 150 HP (total). For single station, single engine use only.

BayStar™

BAYSTAR®
OUTBOARD
STEERING
SYSTEM

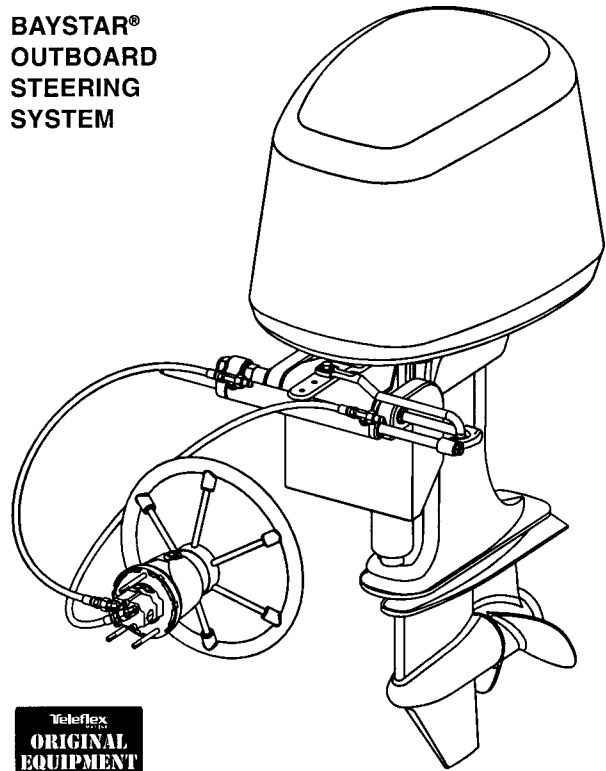

(4.5 turns lock-to-lock)

Tilt
STEERING
available!

Phone: 800-225-0004 ☎ Fax: 908-486-1056
e-mail: sales@sealandpower.com

BayStar outboard steering

Complete Systems:

BayStar kits come complete with everything needed for an install: helm, cylinder, tubing, fittings and fluid. For your convenience two lengths of either 20' or 30' cut-to-fit tubing are supplied.

BayStar Steering Kit (20' tubing set) HK4200
BayStar Steering Kit (30' tubing set) HK4230



Components:

BayStar Front Mount Helm HH4016

BayStar Outboard Cylinder HC4600*

* The cylinder utilizes the outboard engine maker's factory supplied drag link for simplified installation. Please note cylinder dimension requirements. Is the splashwell wide enough? The standard cylinder requires 32" (813mm) splashwell width. Find the dimensions (A, B & C) of your splashwell (see chart and diagram on following pages). Check them against the minimum splashwell dimensions to ensure full movement of engine and cylinder.

HK4200 Tubing (2 x 20' lengths) HT4420

HK4230 Tubing (2 x 30' lengths) HT4430

SeaStar Oil (1 Quart) HA5430 (x2)

BayStar Filler Kit HA5438

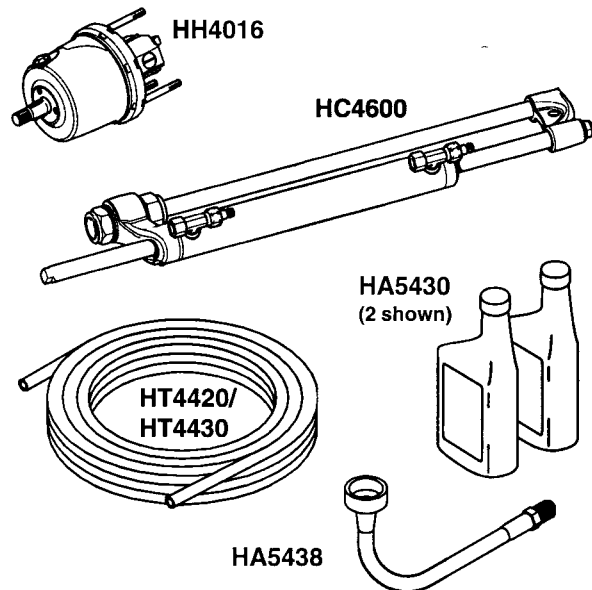

Options:

BayStar Sport Tilt Helm/Mech. HH4015

BayStar Compact Cylinder (optional) .. HC4645

BayStar Compact Cylinder (optional) .. HC4647

BayStar Compact Cylinder (optional) .. HC4658

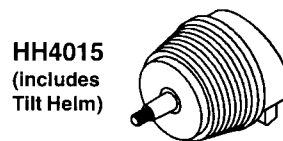

Service Items:

SeaStar Oil (1 Gallon) HA5440

Steering Wheel Locknut 747521

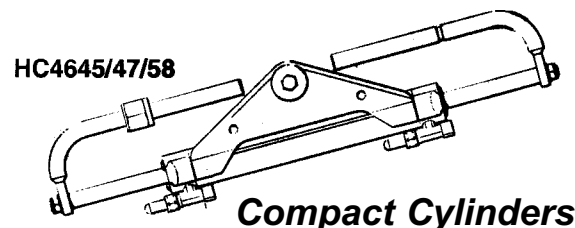

NOTE: HC4600 BayStar standard Cylinder is a universal cylinder, however, ensure it will fit you splashwell. If the splashwell measurements limit the engine to BayStar Compact Steering Cylinders HC4645, HC4647, HC4658, please view the application guide to determine which cylinder is to be used for your engine. BayStar Compact Cylinders are NOT available in kit form, all parts MUST be ordered separately.

Compact Cylinders

Phone: 800-225-0004 Fax: 908-486-1056
e-mail: sales@sealandpower.com

BayStar outboard steering

Compact Cylinders Application Guide:

ENGINE MAKER/ BRAND	YEAR	MODEL	CYLINDER PART NUMBER	NOTES
FORCE	1985 TO DATE	90-150 HP	HC4645	
HONDA	1992 TO DATE	30-90 HP	HC4645	
	1998 TO DATE	115-130 HP	HC4647	
JOHNSON/EVINRUDE <i>Note: Johnson 115 HP 2-stroke engines, required the pivot plate to be flipped. See note #4 below.</i>	1977 TO 1989	65-150 HP	Consult Factory	
	1991 TO DATE	40-150 HP	HC4645	
	1997 TO DATE	115 HP Ficht	HC4658	See note 4.
	1997 TO DATE	75-150 HP Ficht	HC4645	
MERCURY/MARINER	1984 TO DATE	75-150 HP	HC4645	See notes 1,4.
NISSAN	1990 TO DATE	120-140 HP	HC4645	
SUZUKI	1986 TO DATE	150 HP	HC4645	
	1996 ONLY	115-140 HP	N/A	
	1987 TO 2002	115-140 HP	HC4645	See note 1.
	1990 TO 2000	90-100 HP	HC4645	
	1998 TO DATE	40-70 HP 4-stroke	HC4645	See note 1.
TOHATSU	2001 TO DATE	115-140 HP 4-stroke	HC4658	See notes 1,4.
	1990 TO DATE	140-140 HP	HC4645	
YAMAHA	1998 TO DATE	40-50 HP	HC4645	See note 2.
	1998 TO DATE	60 HP	HC4645	See note 3.
	1986 TO DATE	70-90 HP	HC4645	See note 1.
	1997 TO DATE	80-150 HP 4-stroke	HC4645	
	2000 TO DATE	40 & 60 HP 4-stroke	Consult Factory	
YANMAR	1990 TO DATE	27-36 HP	HC4645	See note 1.

NOTES:

- Requires Spacer kit part # HO5090.
- Engine clamp brackets must be cut or ground, and the engine through bolted onto the transom, or interference will occur, restricting engine trim and tilt.
- Steering hook Yamaha Part # 63D-48511-00-4D must be installed.
- Cylinder HC4645 may be used in these applications. The pivot plate will need to be flipped before installation. Instructions provided with Owner's Manual.

Splashwell Size Requirements:

CYL MODEL NO.	NO. OF ENG.	SPLASHWELL DIAG. DIM.			MINIMUM ENGINE CENTER DISTANCE
		A	B	C	
HC4600	1	32" (813 mm)	5" (127 mm)	4" (102 mm)	N/A (N/A)
HC4645/47/58	1	21" (534 mm)	6" (153 mm)	5" (127 mm)	N/A (N/A)

(Twin engine applications not available at this time.)

NOTES:

- Ensure there is no interference between the BayStar cylinder rod (starboard side) and the splashwell boot or engine controls & cables.
- Dimensional restrictions also apply to external motor mount brackets.
- Ensure dimension 'A' maintains 32" (813mm) through full trim/tilt range.
- Maximum transom thickness 3" (76mm).
- Engines less than 70 HP may require up to 1" (25mm) of additional splashwell clearance.

REQUIRED SPLASHWELL DIMENSIONS/ MINIMUM ENGINE CENTER DISTANCES:
(refer to chart at left)

REAR VIEW:

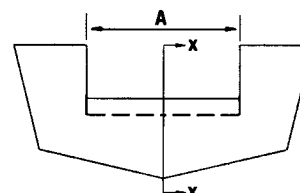

SIDE VIEW:

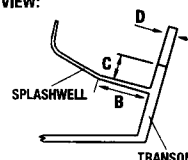

"D" not to exceed 3"

SeaStar outboard steering

Unmatched comfort and control. Only with SeaStar steering. The world's most popular outboard hydraulic system offers smooth, super-efficient steering for today's high performance hulls with single or multiple outboards up to 600 HP combined. It's the OEM Choice for center consoles, cruisers and more.

SeaStar[®]

Features:

- Patented steering lock valves.
- Low friction hydraulic steering system.
- 5 turns from lock-to-lock (single cylinder).
- Compact helm has only a 4-7/16" footprint; needs only 3" dash hole (Tilt requires larger dash cut out).
- Packaged complete with helm, cylinder, fittings, oil, bleeder kit and detailed instructions.
- Standard 3/4" tapered steering shaft.
- Fast, easy installation.
- Meets A.B.Y.C. standards.
- Meets N.M.M.A. certification requirements.

SEASTAR[®]
FRONT MOUNT CYLINDER
OUTBOARD SYSTEM

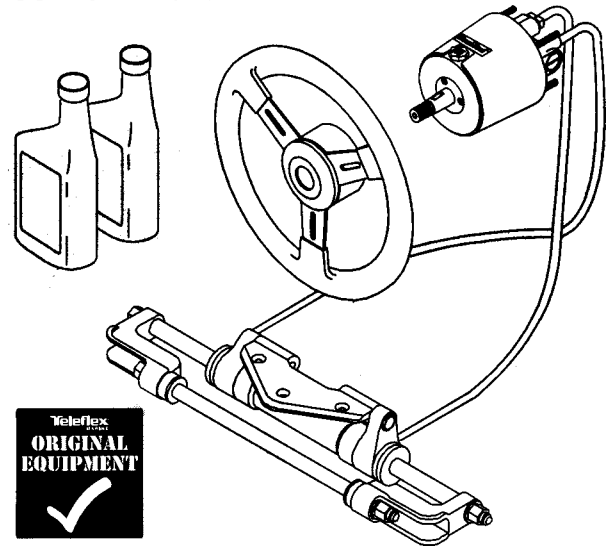

Applications:

Single and dual non-power-assisted outboard engines up to 300 HP (600 combined HP for counter-rotating duals) that have ABYC standard engine tilt tube.

Ideal for cruisers, runabouts, center console boats, offshore fishing boats and many more.

Suitable for speeds up to 60 MPH and dual station use (with purchase of extra helm, hose & fittings).

Allows independent engine tilt in dual engine installations. Dual engines require purchase of a tie bar kit and extra hardware.

(5 turns lock-to-lock)

Tilt[™]
STEERING
available!

Note: Use only SeaStar outboard steering hoses (HO51/HO57 type) with SeaStar outboard steering systems. The use of nylon tubing is not recommended for SeaStar outboard steering.

SeaStar outboard steering

Complete Systems:

SeaStar 1.7 Steering Kit (with Hoses) HK63XX
SeaStar 1.7 Steering Kit (no Hoses) HK6400

Components:

SeaStar 1.7 Helm HH5271

Front Mount Outboard Cylinder HC5345*
(See application guide for some engines which may require HC5347, HC5348 or HC5358.)

SeaStar Hose Kit (2 hoses) HO51__

SeaStar Oil (1 Quart) HA5430 (x2)

Options:

SeaStar 2.4 Helm *(see ordering guide)* .. HH5272

SeaStar 1.7 Sport Tilt Helm/Mech. HH5291

SeaStar 1.7 Traditional Tilt Helm/Mech. . HH5741

SeaStar 2.4 Sport Tilt Helm/Mech. HH5292

SeaStar 2.4 Traditional Tilt Helm/Mech. . HH5742

SeaStar 1.7 Rear Mount Helm HH5261

SeaStar 1.7 Commercial Duty Helm HH5217

SeaStar 2.4 Commercial Duty Helm HH5224

(Designed for small Lobster and Crabbing vessels, these helms have a stainless steel shaft with heavy duty seal and wiper, which help protect the helm from the abrasive effects of sediment brought on board with traps or pots.)

SeaStar Round Bezel Kit HA5417

(Reduces helm protrusion by 3.75")

SeaStar Backplate Kit HA5418

(Reduces helm protrusion by thickness of dash and allows clean retrofit of SeaStar helm where following helms were previously installed: pre-1991 SeaStar, SyTen, and mechanical rotary steering)

SeaStar 20° Dash Wedge Kit HA5419

SeaStar Bulkhead Hose Kit (2 hoses) HO81__

(Allows installation through a bulkhead without additional fittings. See Page 14 for more information.)

SeaStar Twin Engine Tie Bar Kit HO5__

(See Application Guides on next two pages.)

Add-A-Station/Autopilot Fitting Kit HF5501

Service Items:

SeaStar Oil (1 Gallon) HA5440

Steering Wheel Locknut 747521



HH5271

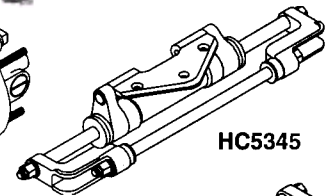
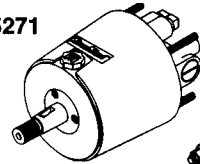

HC5345

HC5347
(some
Honda)

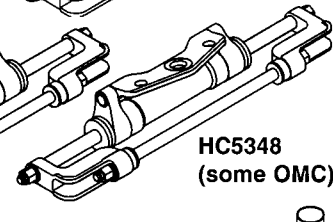
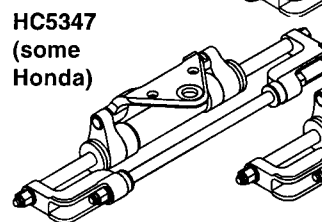

HC5348
(some OMC)

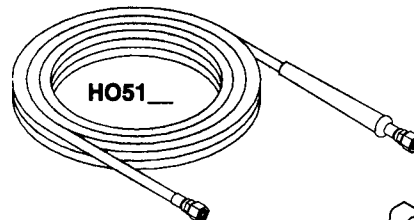

HO51__

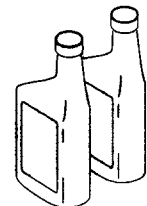

HA5430
(2 shown)

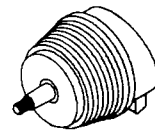

HH5291/HH5292
(includes Tilt Helm)

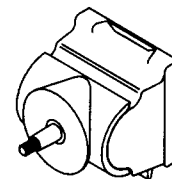

HH5741/HH5742
(includes Tilt Helm)

(Tilt Helm)

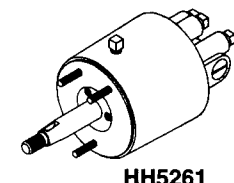
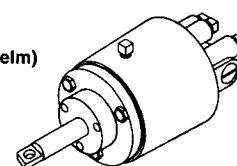

HH5261

HF5501



747521



SeaStar outboard steering

Single & Dual Engine Application Guide:

ENGINE MAKER/ BRAND	YEAR	MODEL	CYLINDER PART NUMBER	TWIN ENGINE 1 CYLINDER TIE BAR KIT (COMPLETE)	TWIN ENGINE 2 CYLINDERS TIE BAR KIT (COMPLETE)	NOTES
FORCE	1985 TO DATE	90-150 HP	HC5345	HO5008A	HO5008A	
HONDA	1996 TO DATE	75-90 HP	HC5345	HO6001	HO6002	See note 3.
	1998 TO DATE	115-130 HP	HC5347	HO5063	HO5064	See note 5.
	1998 TO DATE	30-50 HP	HC5345	HO6001	HO6002	See note 2.
	2001-DATE	150HP 4-stroke	HC5345	HO6003	HO6002	
	2001-DATE	200-225 HP 4-stroke	HC5345	HO6001	HO6002	
JOHNSON/EVINRUDE	1977-1990	65-300 HP	HC5348	HO6001	HO6002	
	1988-1997	250-300 HP V8	HC5342	HO5001A	HO5030	See note 5.
	1991-DATE	40-250 HP	HC5345	HO6003	HO6002	
	1996-DATE	75-250 HP Ficht	HC5345	HO6003	HO6002	
	1998-DATE	40-140 HP 4-stroke	HC5358	HO6003	HO6002	See note 2.
	2000-DATE	115HP Ficht	HC5358	HO6003	HO6002	See note 2.
MERCURY/MARINER	1984 TO 1994	2.4/2.5 EFI	HC5345	HO6001	HO6002	See note 4.
	1989 TO DATE	75-300 HP	HC5345	HO6001	HO6002	See note 3.
	1996-DATE	75-200 HP 2/4-stroke	HC5345	HO6001	HO6002	
	1998 TO DATE	30-60 HP	HC5345	HO6001	HO6002	See note 2.
	2002 TO DATE	225 HP 4-stroke	HC5358	HO6001	HO6002	See note 1.
2003 TO DATE	250 HP XS	HC6345	N/A	(See SKA next page)	See note 6.	
NISSAN/TOHATSU	1990 TO DATE	90-140 HP	HC5345	HO6001	HO6002	
SUZUKI	1986 TO DATE	100 HP	HC5345	HO6003	HO6002	
	1986-2002	115-140 HP	HC5345	HO6001	HO6002	NOT 1996
	1986-DATE	150-250HP 2/4-stroke	HC5345	HO6003	HO6002	
	1996 ONLY	115-140 HP	HC5348	HO6001	HO6002	
	1998 TO DATE	40-140 HP 4-stroke	HC5358	HO6003	HO6002	See note 2.
	2003 TO DATE	90 HP 4-stroke	HC5358	HO6003	HO6002	See note 2.
US MARINE (FORCE)	1996-DATE	90-120 HP	HC5345	HO6001	HO6002	
YAMAHA	1990 TO DATE	40-90 HP	HC5345	HO6003	HO6002	
	1986-DATE	100-250 HP 2-stroke	HC5345	HO6001	HO6002	
	1997-DATE	80-225 HP 4-stroke	HC5358	HO6001	HO6002	See note 1.
	2000-DATE	150-250 HP DI	HC5358	HO6001	HO6002	See note 1.
	2002-DATE	300 HP DI	HC5358	HO6001	HO6002	
	2003-DATE	40-60 HP 4-stroke	HC5348	HO6003	HO6002	See note 2.
YANMAR (DIESEL)	1994 TO DATE	27 & 36 HP	HC5345	HO6001	HO6002	

NOTES:

1. HC5345 is optional for Single Engine ONLY applications. DO NOT use HC5345 for twin engine applications as operational interference may occur.
2. Requires Kit HO5090.
3. Minimum Engine Center = 27"
4. May Require Extensive Cowling Modifications.
5. HO5030 and HO5064 comes without Tie Bar.
6. One cylinder per engine. Must use Mercury supplied tiller bolt for installation.

HO5090 SPACER KIT PARTS LIST

ITEM	P/N	QTY	DESCRIPTION
1	198767	1	Screw 3/8-24 x 1-5/8" Hex Head (Tiller Bolt)
2	113600	1	Fender Washer 3/8" I.D. (stainless steel)
3	773421	1	Spacer 1/2" (aluminum)
4	728994-1	1	Yamaha Spacer 3/16"
5	995876	2	Thick Spacer 3/8" (nylon)

*Interference between the cylinder and boat may occur under certain conditions. Check installation thoroughly throughout the full range of engine tilt and trim (and jackplate movement, if present).

Phone: 800-225-0004  Fax: 908-486-1056
e-mail: sales@sealandpower.com

SeaStar outboard steering

Single & Dual Engine Ordering Guide: Front Mount Systems

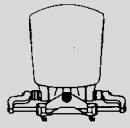
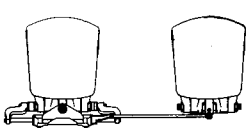
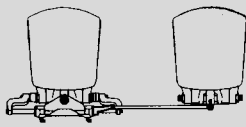
ENGINE/CYLINDER CONFIGURATION	COMPONENT DESCRIPTION	QTY. REQ'D	MODEL	PART NO.	
SINGLE ENGINE (SINGLE CYLINDER) Applications up to 300 HP maximum NUMBER OF TURNS: 5 	CYLINDER (See Application Guide)	1	PIVOT FRONT MOUNT	HC53__	
	HELM	1	SEASTAR 1.7	HH5271	
	HOSE KIT	1	OUTBOARD HOSE	H051__	
	OIL	3	SEASTAR OIL (QT.)	HA5430	
	FOR EXTRA STEERING STATION ADD:				
	HELM	1	SEASTAR 1.7	HH5271	
	FITTING KIT	1	ADD A STATION	HF5501	
	HOSE KIT	1	OUTBOARD HOSE	H051__	
	OIL	1	SEASTAR OIL (QT.)	HA5430	
	DUAL ENGINE (SINGLE CYLINDER) Non-Counter-Rotating Applications to 450 HP max; Counter-Rotating Applications to 600 HP maximum. NUMBER OF TURNS: 5 	CYLINDER (See Application Guide)	1	PIVOT FRONT MOUNT	HC53__
TIE BAR KIT		1	SEE APPLICATION GUIDE	H060__	
HELM		1	SEASTAR 1.7	HH5271	
HOSE KIT		1	OUTBOARD HOSE	H051__	
OIL		3	SEASTAR OIL (QT.)	HA5430	
FOR EXTRA STEERING STATION ADD:					
HELM		1	SEASTAR 1.7	HH5271	
FITTING KIT		1	ADD A STATION	HF5501	
HOSE KIT		1	OUTBOARD HOSE	H051__	
OIL		1	SEASTAR OIL (QT.)	HA5430	
DUAL ENGINE (DUAL CYLINDERS) Non-Counter-Rotating Applications to 450 HP max; All Counter-Rotating Engine Applications NUMBER OF TURNS: 7 	CYLINDER (See Application Guide)	2	PIVOT FRONT MOUNT	HC53__	
	TIE BAR KIT	1	SEE APPLICATION GUIDE	H060__	
	HELM	1	SEASTAR 2.4	HH5272	
	HOSE KIT	1	OUTBOARD HOSE	H051__	
	HOSE KIT	1	OUTBOARD HOSE	H051__	
	HOSE KIT	1	OUTBOARD HOSE	H051__	
	FITTING KIT	1	TEE FITTINGS	HF5530	
	OIL	3	SEASTAR OIL (QT.)	HA5430	
	FOR EXTRA STEERING STATION ADD:				
	HELM	1	SEASTAR 2.4	HH5272	
FITTING KIT	1	ADD A STATION	HF5501		
HOSE KIT	1	OUTBOARD HOSE	H051__		
OIL	1	SEASTAR OIL (QT.)	HA5430		

For all Seastar outboard systems: Use following option A or B:

A) Outboard hose: order in standard lengths (cannot be cut to length.)

B) Copper tube: 3/8" diameter copper tube and hose kit part No. HF5508.

TYPICAL FRONT MOUNT TIE BAR KIT FOR HC5345 FRONT MOUNT CYLINDER (HO6001/HO6002/HO6003)

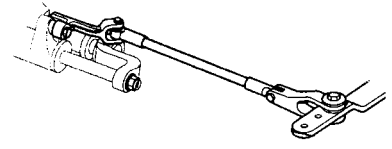

NUMBER OF ENGINES	SPLASHWELL DIAGRAM DIMENSION			MINIMUM ENGINE CENTER DISTANCE
	A	B	C	
1	22" (559mm)	6" (152mm)	5" (127mm)	N/A
2	44" (1118mm)	6" (152mm)	5" (127mm)	26" (660mm)
3	66" (1677mm)	6" (152mm)	5" (127mm)	29" (737mm)

NOTE: MAXIMUM ENGINE CENTER DISTANCE: 36" (914mm) USING THE STANDARD SEASTAR TIE BAR

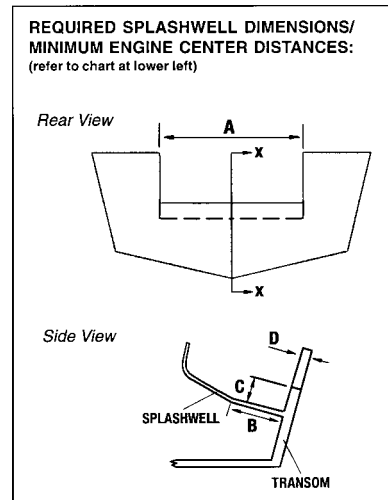

Phone: 800-225-0004 Fax: 908-486-1056
 e-mail: sales@sealandpower.com

Hynautic stern drive steering

This system is designed for stern drive, outboard and inboard boats requiring external cylinders of substantial size and strength. The K-5 cylinders are nickel plated for aesthetics and protection against the elements.

System components are sold separately. The required wing plates and hardware are not available from Teleflex.

Systems can be selected using either the easy-to-install Capilano 2-line systems (with variable-displacement helm) or the traditional Hynautic 3-line configurations.

Capilano Components:

- Capilano 1275V Helm HH5275
- External Stern Drive Cylinder K-5 (2 required)
- Copper Tubing 1/2" or 5/8" OD
- Fitting Kit (for 1/2" Copper Tubing) HF5590 or
- Fitting Kit (for 5/8" Copper Tubing) HF5592
- These fitting kits are for one steering station (purchase add-a-station kit for 2nd station).*
- Capilano Steering Fluid Dexron II® ATF

Options:

- Add-A-Station Fitting Kit (1/2" tubing) HF5591
- Add-A-Station Fitting Kit (5/8" tubing) HF5593
- Helm Remote Fill Kit (through-dash) HA5450

Service Items:

- Steering Fluid Dexron II® ATF
- Steering Wheel Locknut 747521

Tubing Diameters:

HELM TYPE	DISTANCE – CYLINDER TO FURTHEST HELM	
	40 Feet or Less	More Than 40 Feet
ALL	1/2" O.D. Copper Tubing	5/8" O.D. Copper Tubing

SeaStar

capilano

HynaUTIC

CAPILANO®/HYNAUTIC®
HEAVY DUTY STERN DRIVE SYSTEM

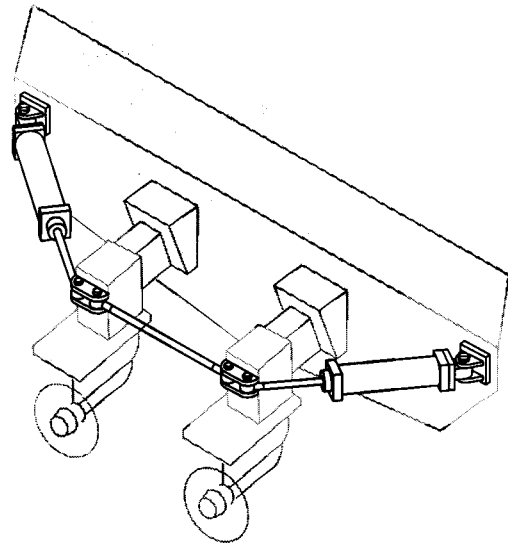

(turns vary by system)

Hynautic stern drive steering

Hynautic Components:

- Hynautic 4.0 cu. in. helm
(1" straight shaft) H-42 or
- Hynautic 4.0 cu. in. helm
(3/4" tapered shaft) H-42-02 or
- Hynautic 5.5 cu. in. helm
(1" straight shaft) H-41 or
- Hynautic 5.5 cu. in. helm
(3/4" tapered shaft) H-41-02 or
- (See application guide.)
- H-40 Fittings Kit for Main Station HF-21
- H-40 Fittings Kit for Second Station HF-22
- External Stern Drive Cylinder K-5 (2 required)
- (See application guide. Fittings available separately.)
- Reservoir - Standard (2 quart) R06
- Relief Valve (950 PSI) MSV-21
- Relief Fittings MSVF-07
- Relief Fittings MSVF-13
- Copper Tubing 1/2" or 5/8" OD
- Fitting Kit (for 1/2" Copper Tubing) HF5590 or
- Fitting Kit (for 5/8" Copper Tubing) HF5592
- These fitting kits are for one steering station (purchase add-a-station kit for 2nd station).*
- SeaStar Oil (1 Quart Mil Spec H5606) HA5430

Options:

- Reservoir (2 quart, with hand pump) R07
- Reservoir (1 quart, with hand pump) R11
- Reservoir (2 quart) R12
- Relief Valve (500 PSI) MSV-19
- Reservevalve (500 PSI, top read, 3/8) RV-55
- Reservevalve (500 PSI, top read, 3/8, w/pump) .. RV-55P
- Reservevalve (500 PSI, top read, 5/16, w/pump) RV-57
- Reservevalve (950 PSI, top read, 5/16) RV-60
- Reservevalve (950 PSI, frt.read, 5/16, w/pump) RV-67
- Add-A-Station Fitting Kit (1/2" tubing) HF5591
- Add-A-Station Fitting Kit (5/8" tubing) HF5593

Helm Options:

HELM PART #	HELM DISPLACEMENT RANGE	NUMBER OF WHEEL TURNS LOCK-TO-LOCK	RELIEF VALVE SETTING
USING CAPILANO (VARIABLE DISPLACEMENT) HELM:			
HH5275	2.7-5.4 cu.in.	10.3-5.2	1000 PSI
USING HYNAUTIC (FIXED DISPLACEMENT) HELMS:			
H-42	4.0 cu. in.	7.0	950 PSI
H-41	5.5 cu. in.	5.1	950 PSI

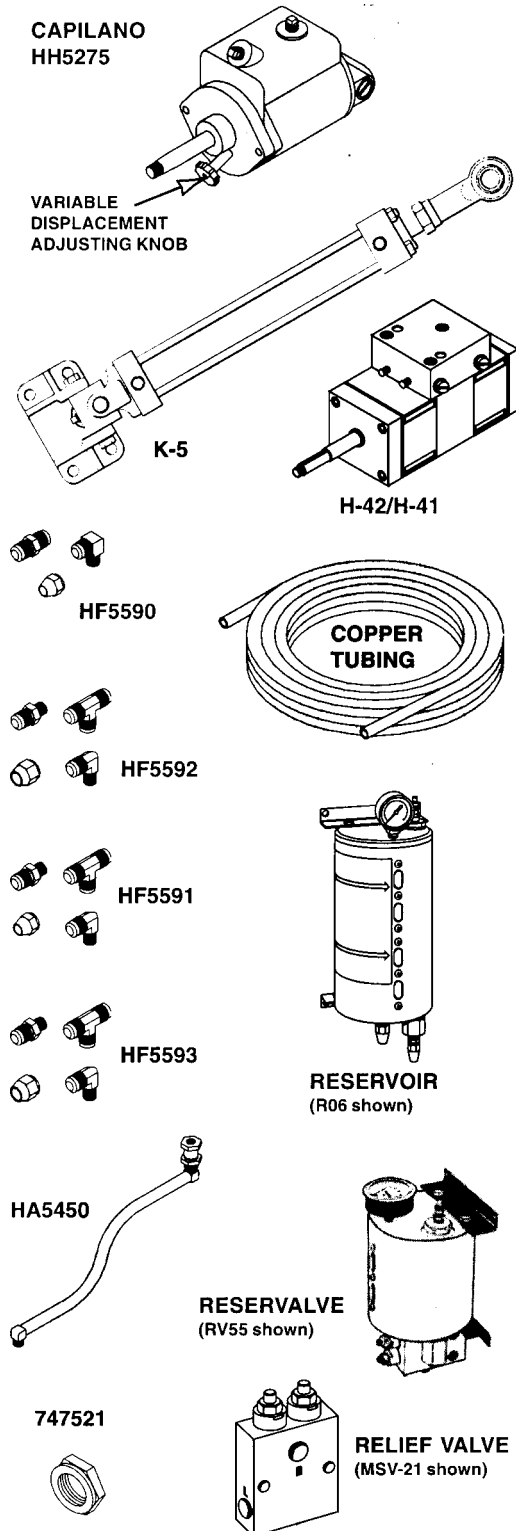

SeaStar stern drive steering

SeaStar Stern Drive Steering is the best choice for non-power assisted stern drives and any stern drive boat with an autopilot. The system is based upon the SeaStar helm family, which allows for dual station and autopilot use. Cylinders are specific to drive brands and models.

SeaStar®

SEASTAR®
STERN DRIVE SYSTEM



Features:

- Best and Most Economical autopilot interface for stern drives! Easy installation.
- Simple multiple steering station connection.
- Optional SeaStar 2.0 & 2.4 helms for quicker steering response.
- Standard 3/4" tapered steering shaft.
- Fast, easy installation.
- Meets A.B.Y.C. standards.
- Meets N.M.M.A. certification requirements.

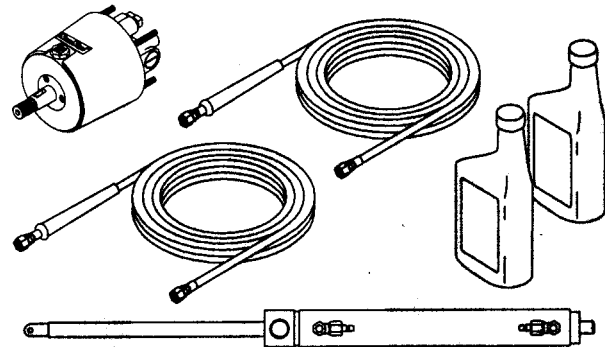

Applications:

Ideal for most stern drives, especially non-power-assisted units, SeaStar is suitable for single and multiple drives and dual stations.

(turns vary by system)



How to Spec a System:

1. From the application guide, confirm that a cylinder is available for your specific make, model and year of drive unit. Select the cylinder that is appropriate for the drive.
2. From the ordering guide, select the appropriate helm and accessory hardware. Note that three SeaStar helm displacements are available for power steered stern drives (1.7, 2.0 & 2.4 cu. in.) **The displacement of the helm affects the number of turns lock-to-lock. Lower helm displacement = more turns = less effort/slower response.** Select helm size on the basis of the desired steering response. *The 2.4 cu. in. version is not recommended for non-power-steered applications.*
3. Select the appropriate tube or hose and fitting kits required for the installation.
4. Confirm that there is sufficient space available in the dash and engine compartment(s) for the steering components.

SeaStar stern drive steering

Components:

- SeaStar 1.7 Helm HH5271
(See Ordering Guide to select helm.)
- Stern Drive Cylinder HC53___
(See Application Guide to select cylinder.)
- Hose Kit (2 hoses) HO51___
- SeaStar Oil (1 Quart) HA5430

Options:

- SeaStar 2.0 Helm HH5273
- SeaStar 2.4 Helm HH5272

- SeaStar 1.7 Sport Tilt Helm/Mech. HH5291
- SeaStar 1.7 Traditional Tilt Helm/Mech. . HH5741
- SeaStar 2.4 Sport Tilt Helm/Mech. HH5292
- SeaStar 2.4 Traditional Tilt Helm/Mech. . HH5742

- SeaStar 1.7 Rear Mount Helm HH5261
- SeaStar 2.4 Rear Mount Helm HH5262

- SeaStar 1.7 Commercial Duty Helm HH5217
- SeaStar 2.4 Commercial Duty Helm HH5224
(Designed for small Lobster and Crabbing vessels, these helms have a stainless steel shaft with heavy duty seal and wiper, which help protect the helm from the abrasive effects of sediment brought on board with traps or pots.)

- SeaStar Round Bezel Kit HA5417
(Reduces helm protrusion by 3.75")

- SeaStar Backplate Kit HA5418
(Reduces helm protrusion by dash thickness and allows clean retrofit of SeaStar helm where following helms were installed: pre-1991 SeaStar, SyTen, and mechanical rotary steering.)

- SeaStar 20° Dash Wedge Kit HA5419

- SeaStar Bulkhead Hose Kit (2 hoses) HO81___
(Allows installation through a bulkhead without additional fittings.)

- Add-A-Station Kit (all helms) HF5502
- Autopilot Fittings Kit (all helms) HF5502
- 3/8" Tubing *(see ordering guide)* HT5___
(Nylon tube intended for use on Sterndrives and inboard steering systems using the SeaStar 1.7 helm ONLY.)

Service Items:

- SeaStar Oil (1 Gallon) HA5440
- Steering Wheel Locknut 747521

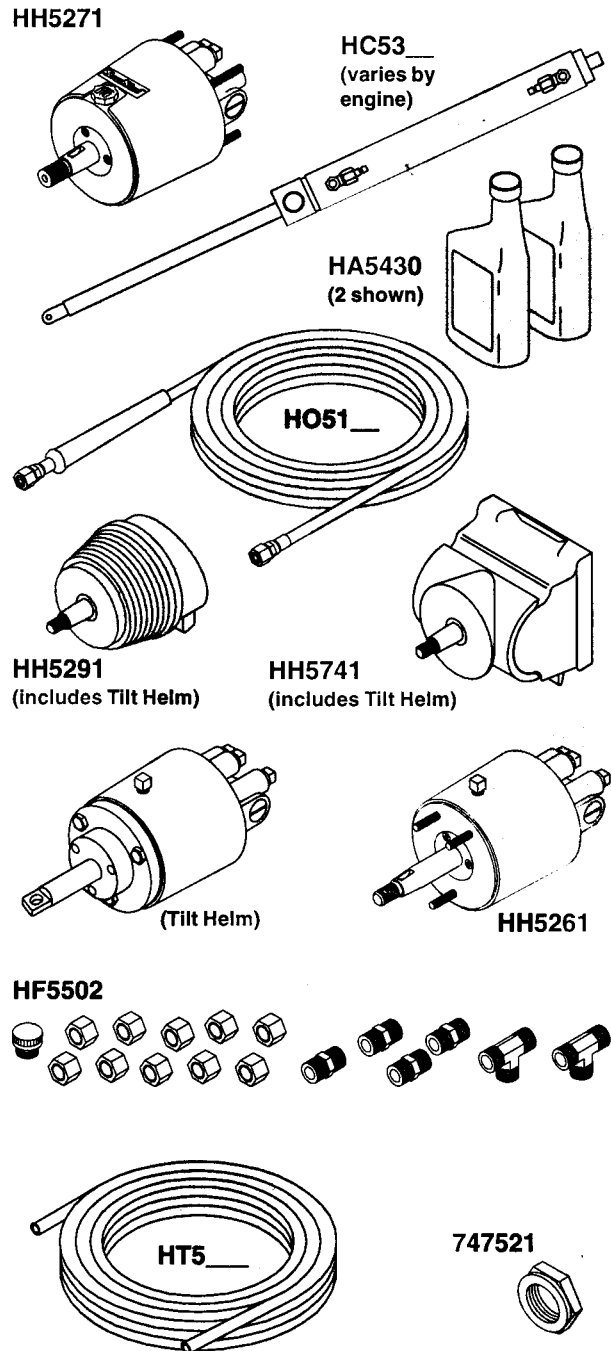

SeaStar stern drive steering

Application Guide: Stern Drive Steering

ENGINE MAKER/ BRAND	STEERING CONFIG.	ENGINE/ DRIVE MODEL	YEAR	(CYLINDER USED)		(NUMBER OF WHEEL TURNS)		NOTES
				MODEL	PART #	SEASTAR (1.7 cu.in.)	SEASTAR (2.4 cu.in.)	
BMW	Non Power	ALL	TO DATE	BA125-8EMV	HC5330	4.9	N/A	1
	Power Assist	ALL	TO DATE	125-8EM	HC5328	4.9/5.8	3.4/4.1	2
MERCUISER	Non Power	MerCruiser I	TO 1983	BA125-8EMV	HC5330	4.9	N/A	1,7
	Non Power	Alpha I	1984 TO DATE	BA135-7EM	HC5332	5.0	3.5	1,5,6,7
	Non Power	Bravo I, II, III	1984 TO DATE	BA135-7EM	HC5332	5.0	3.5	1,5,6,7
	Power Assist	MerCruiser I	TO 1983	125-8EM	HC5328	4.9/5.8	3.4/4.1	2
	Power Assist	Alpha I	1984 TO DATE	125-8EM	HC5328	4.9/5.8	3.4/4.1	2
	Power Assist	Bravo I, II	1984 TO DATE	125-8EM	HC5328	4.9/5.8	3.4/4.1	2
	Power Assist	Bravo III	1984 TO DATE	125-8EM	HC5328	4.9/5.8	3.4/4.1	2,8
OMC	Non Power	400/800 Series	TO 1985	N/A	N/A	N/A	N/A	
	Non Power	Cobra	1986 TO DATE	BA150-7EM	HC5326	6.0	N/A	1,4
	Non Power	King Cobra	1986 TO DATE	BA150-7EM	HC5326	6.0	N/A	1,4
	Power Assist	400/800 Series	TO 1985	N/A	N/A	N/A	N/A	
	Power Assist	Cobra	1986 TO DATE	125-8EM	HC5328	4.9/5.8	3.4/4.1	2
	Power Assist	King Cobra	1986 TO DATE	125-8EM	HC5328	4.9/5.8	3.4/4.1	2
VOLVO	Non Power	275	TO DATE	BA150-7ATM	HC5314	6.0	N/A	1,7
	Non Power	280, 290	TO DATE	BA135-7EM	HC5332	5.0	3.5	1,5,6,7
	Non Power	Diesel	TO DATE	BA135-7EM	HC5332	5.0	3.5	1,5,6,7
	Power Assist	275	TO DATE	N/A	N/A	N/A	N/A	
	Power Assist	280, 290	TO DATE	125-8EM	HC5328	4.8/5.8	3.4/4.1	2
	Power Assist	Diesel	TO DATE	125-8VEM	HC5329	4.9/5.8	3.4/4.1	2
	Power Assist	32, Diesel	1997 TO DATE	92-VPS	HC5331	4.8/5.5	3.4/4.1	2
	Power Assist	41-42, Diesel	1992 TO DATE	92-VPS	HC5331	4.8/5.8	3.4/4.1	2
	Power Assist	DPS & SX	1996 TO DATE	92-VPS	HC5331	4.9/5.5	3.4/4.1	2
YAMAHA	Non Power	ALL	1989 TO DATE	N/A	N/A	N/A	N/A	
	Power Assist	ALL	1989 TO 1992	125-8EM	HC5328	4.9/5.8	3.4/4.1	2

NOTES:

N/A = Not Available.

- Balanced system - number of steering wheel turns lock-to-lock is equal port to starboard or vice-versa.
- Unbalanced system - number of steering wheel turns lock-to-lock is unequal port to starboard or vice-versa.
- Requires additional clevis supplied by engine manufacturer. Reference Quicksilver Part No. B98735A1.
- Requires cylinder rod end adapter HA5424 from Teleflex Canada Limited Partnership.
- HC5332 replaces HC5326 as of January 2000. If installing HC5326 additional clevis supplied by engine manufacturer required (part number B98735A1).
- The installation of the HC5332 sterndrive cylinder requires the use of SeaStar Outboard hose only. Do not use 3/8" copper or nylon tube.
- If engine outdrive is NOT equipped with a torque tab on the underside of the lower leg one must be installed to reduce prop torque.
- Yanmar Engines using the Bravo III drives require the use of cylinder HC5326.

Phone: 800-225-0004  Fax: 908-486-1056
e-mail: sales@sealandpower.com

SeaStar stern drive steering

Ordering Guide: Stern Drive Steering

ENGINE/CYLINDER CONFIGURATION	COMPONENT DESCRIPTION	QTY. REQ'D	MODEL	PART NO.
SINGLE & DUAL STERN DRIVES (Number of Turns varies by Helm & Cylinder. See Application Guide.) For dual sterndrive applications use engine manufacturers supplied tie bar.	CYLINDER	1	SEE APPLICATION GUIDE	HC53__
	HELM	1	SEASTAR 1.7 (SEE NOTE 1)	HH5271
	HELM (OPTIONAL)		SEASTAR 2.4 (SEE NOTE 2)	HH5272
	TUBING/HOSE		(SEE NOTE 3)	
	OIL	3	SEASTAR OIL (QT.)	HA5430
	FOR EXTRA STEERING STATION ADD:			
	HELM	1	SEASTAR 1.7 (SEE NOTE 1) SEASTAR 2.4 (SEE NOTE 2)	HH5271 HH5272
	FITTING KIT	1	ADD A STATION • FOR SEASTAR 1.7 HELM • FOR SEASTAR 2.4 HELM	HF5502 HF5501
	OIL	1	SEASTAR OIL	
	EXTRA TUBE/HOSE		(SEE NOTE 3)	
OPTIONAL EQUIPMENT	BACK PLATE KIT		(FRONT MOUNT HELMS)	HA5418
	20 DEGREE WEDGE		(FRONT MOUNT HELMS)	HA5419
	AUTOPILOT FITTING KIT		(FOR ALL HELMS)	HF5502
	TILT HELM - SEASTAR 1.7			HH5741
	REAR MOUNT HELM - SEASTAR 1.7			HH5261
	TILT HELM - SEASTAR 2.4			HH5742
	REAR MOUNT HELM - SEASTAR 2.4			HH5262

NOTE: These recommendations apply to factory stock sterndrives only. Modified installations may require a higher capacity steering system. If in doubt, contact our technical service for assistance.

- SeaStar 1.7 helms are the standard recommendation for both non-power and power steered applications.
- SeaStar 2.4 helms can be specified for power steered applications where faster steering response is desired. Review the Application Guide on the previous page for recommendations.
- For SeaStar 1.7 systems, use 3/8" diameter nylon tubing (Part No. HT5___).
For SeaStar 2.4 systems, use the following option A or B:
A. Outboard Hose: hoses must be ordered in standard lengths. They cannot be cut to length.
B. Copper tube: 3/8" diameter copper tube and hose kit (Part No. HF5508).
- For dual stern drives: use the tie bar supplied by the engine manufacturer.

SeaStar Autopilot Interface

SeaStar is the best steering choice to interface with most autopilots. If you are installing an autopilot on a mechanically steered boat, we recommend you upgrade to SeaStar for performance reasons.

If you're upgrading to SeaStar, plan ahead: future installation of an autopilot or extra steering station can be simplified by installing two pairs of shorter hose kits. Connect them with union coupling fittings, part no. HF5530. Tee fittings can be installed with ease at a later date. Bulkhead union fitting kits are available to facilitate hose runs through transoms and splashwells:

- HF5512 up to 3/4" (19mm) splashwell, 1 cylinder
- HF5513 up to 3" (76mm) transom, 1 cylinder
- HF5514 up to 3/4" (19mm) splashwell, 2 cylinders
- HF5515 up to 3" (76mm) transom, 2 cylinders

For an autopilot installation, a third (compensating) line must be installed and identified. (SeaStar helm Ports marked "R" are for connection of additional helm and/or autopilot compensating lines.) Use HF5501 (outboards) or HF5502 (stern drives and inboards) fitting kits when adding an autopilot to your SeaStar system.

